

DLM12S

2000W Powered Subwoofer with DLP Digital Processor

OWNER'S MANUAL



Important Safety Instructions

1. Read these instructions.
2. Keep these instructions.
3. Heed all warnings.
4. Follow all instructions.
5. Do not use this apparatus near water.
6. Clean only with a dry cloth.
7. Do not block any ventilation openings. Install in accordance with the manufacturer's instructions.
8. Do not install near any heat sources such as radiators, heat registers, stoves, or other apparatus (including amplifiers) that produce heat.
9. Do not defeat the safety purpose of the polarized or grounding-type plug. A polarized plug has two blades with one wider than the other. A grounding-type plug has two blades and a third grounding prong. The wide blade or the third prong are provided for your safety. If the provided plug does not fit into your outlet, consult an electrician for replacement of the obsolete outlet.
10. Protect the power cord from being walked on or pinched particularly at plugs, convenience receptacles, and the point where they exit from the apparatus.
11. Only use attachments/accessories specified by the manufacturer.
12. Use only with a cart, stand, tripod, bracket, or table specified by the manufacturer, or sold with the apparatus. When a cart is used, use caution when moving the cart/apparatus combination to avoid injury from tip-over.
13. Unplug this apparatus during lightning storms or when unused for long periods of time.
14. Refer all servicing to qualified service personnel. Servicing is required when the apparatus has been damaged in any way, such as power-supply cord or plug is damaged, liquid has been spilled or objects have fallen into the apparatus, the apparatus has been exposed to rain or moisture, does not operate normally, or has been dropped.
15. This apparatus shall not be exposed to dripping or splashing, and no object filled with liquids, such as vases or beer glasses, shall be placed on the apparatus.
16. Do not overload wall outlets and extension cords as this can result in a risk of fire or electric shock.
17. This apparatus has been designed with Class-I construction and must be connected to a mains socket outlet with a protective earthing connection (the third grounding prong).
18. This apparatus has been equipped with a rocker-style AC mains power switch. This switch is located on the rear panel and should remain readily accessible to the user.
19. The MAINS plug or an appliance coupler is used as the disconnect device, so the disconnect device shall remain readily operable.



20. NOTE: This equipment has been tested and found to comply with the limits for a Class B digital device, pursuant to part 15 of the FCC Rules. These limits are designed to provide reasonable protection against harmful interference in a residential installation. This equipment generates, uses, and can radiate radio frequency energy and, if not installed and used in accordance with the instructions, may cause harmful interference to radio communications. However, there is no guarantee that interference will not occur in a particular installation. If this equipment does cause harmful interference to radio or television reception, which can be determined by turning the equipment off and on, the user is encouraged to try to correct the interference by one or more of the following measures:

- Reorient or relocate the receiving antenna.
- Increase the separation between the equipment and the receiver.
- Connect the equipment into an outlet on a circuit different from that to which the receiver is connected.
- Consult the dealer or an experienced radio/TV technician for help.

CAUTION: Changes or modifications to this device not expressly approved by LOUD Technologies Inc. could void the user's authority to operate the equipment under FCC rules.

21. This apparatus does not exceed the Class A/Class B (whichever is applicable) limits for radio noise emissions from digital apparatus as set out in the radio interference regulations of the Canadian Department of Communications.

ATTENTION — *Le présent appareil numérique n'émet pas de bruits radioélectriques dépassant les limites applicables aux appareils numériques de class A/de class B (selon le cas) prescrites dans le règlement sur le brouillage radioélectrique édicté par les ministere des communications du Canada.*

22. Exposure to extremely high noise levels may cause permanent hearing loss. Individuals vary considerably in susceptibility to noise-induced hearing loss, but nearly everyone will lose some hearing if exposed to sufficiently intense noise for a period of time. The U.S. Government's Occupational Safety and Health Administration (OSHA) has specified the permissible noise level exposures shown in the following chart.

According to OSHA, any exposure in excess of these permissible limits could result in some hearing loss. To ensure against potentially dangerous exposure to high sound pressure levels, it is recommended that all persons exposed to equipment capable of producing high sound pressure levels use hearing protectors while the equipment is in operation. Ear plugs or protectors in the ear canals or over the ears must be worn when operating the equipment in order to prevent permanent hearing loss if exposure is in excess of the limits set forth here:

Duration, per day in hours	Sound Level dBA, Slow Response	Typical Example
8	90	Duo in small club
6	92	
4	95	Subway Train
3	97	
2	100	Very loud classical music
1.5	102	
1	105	John screaming at Troy about deadlines
0.5	110	
0.25 or less	115	Loudest parts at a rock concert

CAUTION

RISK OF ELECTRIC SHOCK. DO NOT OPEN

CAUTION: TO REDUCE THE RISK OF ELECTRIC SHOCK DO NOT REMOVE COVER (OR BACK) NO USER-SERVICEABLE PARTS INSIDE. REFER SERVICING TO QUALIFIED PERSONNEL

The lightning flash with arrowhead symbol within an equilateral triangle is intended to alert the user to the presence of uninsulated "dangerous voltage" within the product's enclosure, that may be of sufficient magnitude to constitute a risk of electric shock to persons.

The exclamation point within an equilateral triangle is intended to alert the user of the presence of important operating and maintenance (servicing) instructions in the literature accompanying the appliance.

WARNING — To reduce the risk of fire or electric shock, do not expose this apparatus to rain or moisture.

Correct Disposal of this product: This symbol indicates that this product should not be disposed of with your household waste, according to the WEEE Directive (2002/96/EC) and your national law. This product should be handed over to an authorized collection site for recycling waste electrical and electronic equipment (EEE). Improper handling of this type of waste could have a possible negative impact on the environment and human health due to potentially hazardous substances that are generally associated with EEE. At the same time, your cooperation in the correct disposal of this product will contribute to the effective usage of natural resources. For more information about where you can drop off your waste equipment for recycling, please contact your local city office, waste authority, or your household waste disposal service.

Contents

- Important Safety Instructions** 2
- Contents**..... 3
- Features** 3
- Introduction** 4
- How To Use This Manual** 4
- Getting Started**..... 4
- Things To Remember**..... 4
- Hookup Diagrams**..... 5

- DLM12S Subwoofer: Rear Panel Features**..... 9
 - 1. Power Connection** 9
 - 2. Power Switch**..... 9
 - 3. Fan Vents** 9
 - 4. XLR Inputs** 9
 - 5. Normal / Invert Switch [Polarity]**..... 10
 - 6. High Pass Outputs** 10
 - 7. Full Range Outputs**..... 10
 - 8. Stereo / Mono Switch [Full Range]**..... 10
 - 9. OLED Display** 11
 - 10. VOL Button**..... 11
 - 11. XVR Button** 11
 - 12. Front LED On / Limit / Off**..... 11
 - 13. DLY Button** 11
 - 14. MEM Button** 11
 - 15. Control Lock** 12
 - 16. + and – Buttons**..... 12
 - 17. 2000W/2W Switch**..... 12

- Smart Protect** 13
 - Limiting**..... 13
 - Overexcursion Protection** 13
 - Thermal Protection**..... 13
 - FYI** 13
- AC Power** 13

- Placement**..... 14
- The Ins and Outs of Polarity** 14
- Care and Maintenance** 14

- Appendix A: Service Information** 15
- Appendix B: Connections** 17
- Appendix C: Technical Information** 18
 - DLM12S Subwoofer Dimensions**..... 19
 - DLM12S Subwoofer Frequency Response**..... 19
 - DLM12S Subwoofer Block Diagram** 20

- Mackie Limited Warranty**..... 21

Features

- 2000W power via ultra-efficient Class-D amplification
- High-power 12", heat-treated woofer with 3" voice coil
- Ultra-low frequency extension hits hard down to 35 Hz
- DLP Digital Processor
 - Powerful, one-touch digital processor with bright OLED screen
 - Precision digital crossover
 - Presets for use with DLM and SRM Series full-range loudspeakers
 - Variable crossover control for optimization with any loudspeaker
 - Six total XLR connectors for flexible I/O control
 - Two line level inputs
 - Two full-range outputs for side fills, additional subwoofers, etc.
 - Two high-pass outputs for direct connection to DLM or other full-range loudspeakers
- Unmatched system control for professional applications
 - Alignment delay up to 300ms for delay stack, balcony, etc.
 - Three memory locations for instant venue setting recall
 - Smart Protect DSP dynamically protects amp/driver
- Innovative ultra-compact design
 - Highest-output compact subwoofer on the market
 - Fit an entire DLM system in nearly any car
 - Stack them up for storage
 - Pole-mount a DLM8 or DLM12
 - Extremely durable 15mm poplar cabinet
 - Rugged, powder-coated 20 gauge steel grille
 - Ridiculously lightweight [48 lb / 21.7 kg]

Introduction

Packing huge power and deep low end into the highest-output compact subwoofer on the market, the Mackie DLM12S 12" Powered Subwoofer delivers 2000 watts of chest-pounding power into any system.

The DLM12S features an integrated Mackie DLP digital processor, offering intuitive one-touch control over all of the tools you demand for your professional sound system. A precision digital crossover optimizes any loudspeaker, including perfect presets for your Mackie full-range loudspeakers. There's even alignment delay for larger system deployment and Smart Protect technology that protects your investment.

The rugged 15mm poplar cabinet is unbelievably compact with a durable, powder-coated grille and integrated pole-cup. Pair it with a Mackie DLM series full-range loudspeaker for the most powerful compact sound system ever.

The new shape of sound – Mackie DLM12S.

How to Use This Manual:

After this introduction, a getting started guide will help you get things set up fast. The hookup diagrams show some typical setups, while the remaining sections provide details of the DLM12S subwoofer.



This icon marks information that is critically important or unique to the subwoofer. For your own good, read and remember them.



This icon leads you to in-depth explanations of features and practical tips. They usually have some valuable nuggets of information.



This icon draws attention to certain features and functions relating to the usage of the subwoofer.

Getting Started

The following steps will help you set up the subwoofers quickly.

1. Make all initial connections with the power switches OFF on all equipment. Make sure the master volume, level, or gain controls are all the way down.
2. Connect the line-level outputs from the mixing console (or other signal source) to the XLR inputs on the rear panel of the DLM12S subwoofers.
3. Connect the high pass outputs from the DLM12S subwoofers to the inputs of powered loudspeakers (or to an amplifier powering passive loudspeakers).
4. Connect the supplied AC power cords to the IEC sockets on the rear panel of each subwoofer. Plug the other end into an AC outlet properly configured with the correct voltage as indicated to the left of the IEC socket.
5. Turn the mixer (or other signal source) on.
6. Turn the subwoofers on.
7. Turn the loudspeakers on.
8. Start the signal source and raise the mixer's main L/R fader up until audio may be heard.
9. Adjust the master volume of the mixer to a comfortably loud listening level.
10. Read the rest of this manual to learn how to use the DLP integrated digital processor to really dial in a sound for the venue.

Things to Remember:

- Never listen to loud music for prolonged periods. Please see the Safety Instructions on page 2 for information on hearing protection.
- As a general guide, the mixer (or other signal source) should be turned on first, DLM12S subwoofers next, and loudspeakers last. As such, the loudspeakers should also be turned off first, followed by the subwoofers, then the mixer. This will reduce the possibility of any turn-on or turn-off thumps and other noises generated by any upstream equipment from coming out of the speakers.
- Save the shipping boxes and packing materials! You may need them someday. Besides, the cats will love playing in them and jumping out at you unexpectedly. Remember to pretend like you are surprised!
- Save your sales receipt in a safe place.

Hookup Diagrams

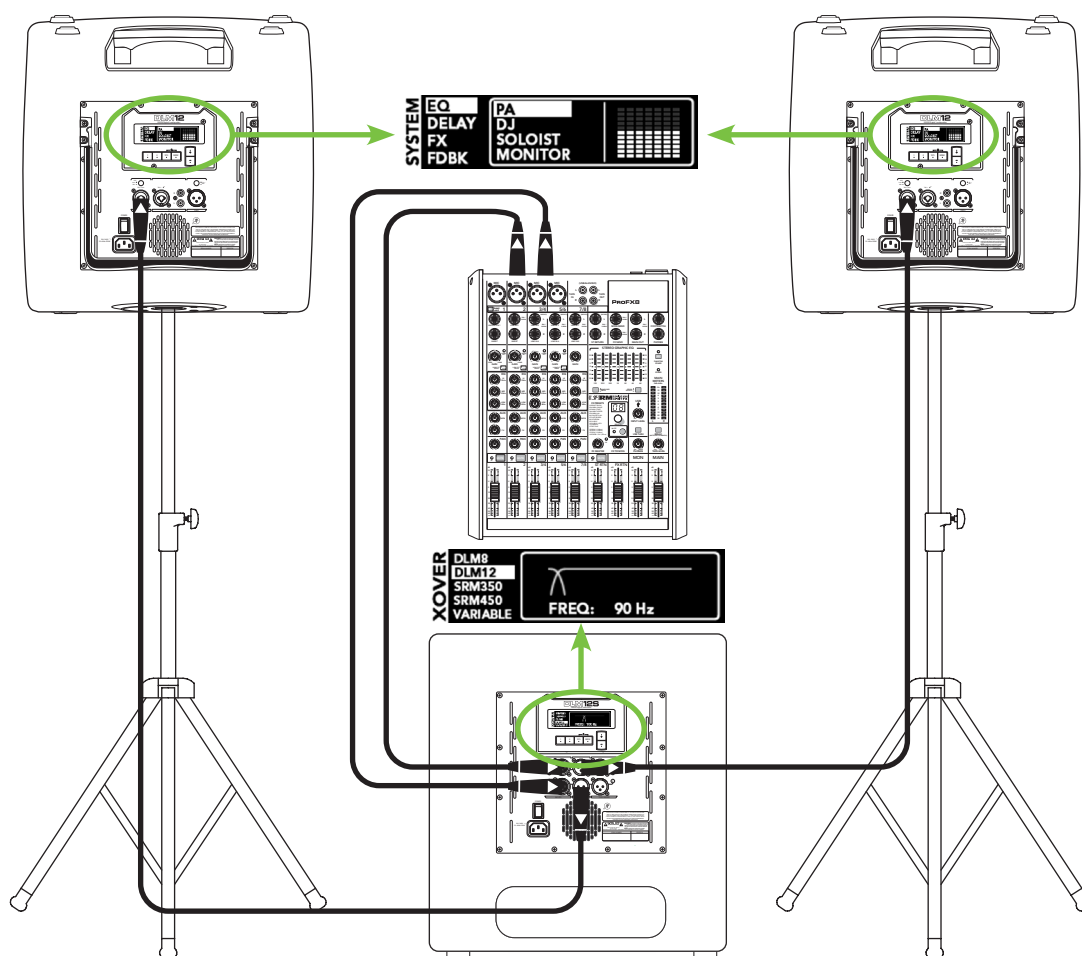

In this example, a Mackie DLM12S subwoofer is connected to two DLM loudspeakers. It is a perfect setup for a small club.

Here, the L/R outputs of a Mackie ProFX8 mixer are connected directly to the channel A and B inputs of a single Mackie DLM12S subwoofer.

The channel A and B high pass outputs of the Mackie DLM12S subwoofer are connected directly to the channel 1 inputs of each DLM loudspeaker. Be sure the mic/line switch is OUT. Or be ready to be blasted with an additional 30 dB! Select the DLM12 crossover on the DLM12S for a perfectly matched system tuning.

DLM loudspeakers are also perfect for using as stage monitors. Simply connect a cable from each aux send to the channel 1 input of each DLM loudspeaker used as a monitor.

For the output, you will want to set a speaker mode, described in detail in the DLM loudspeaker manual. For this type of setup, we recommend selecting the PA speaker mode for live sound on your DLM loudspeakers. If using any DLM loudspeakers as monitors, select the monitor speaker mode.

Small Club System

Hookup Diagrams continued...

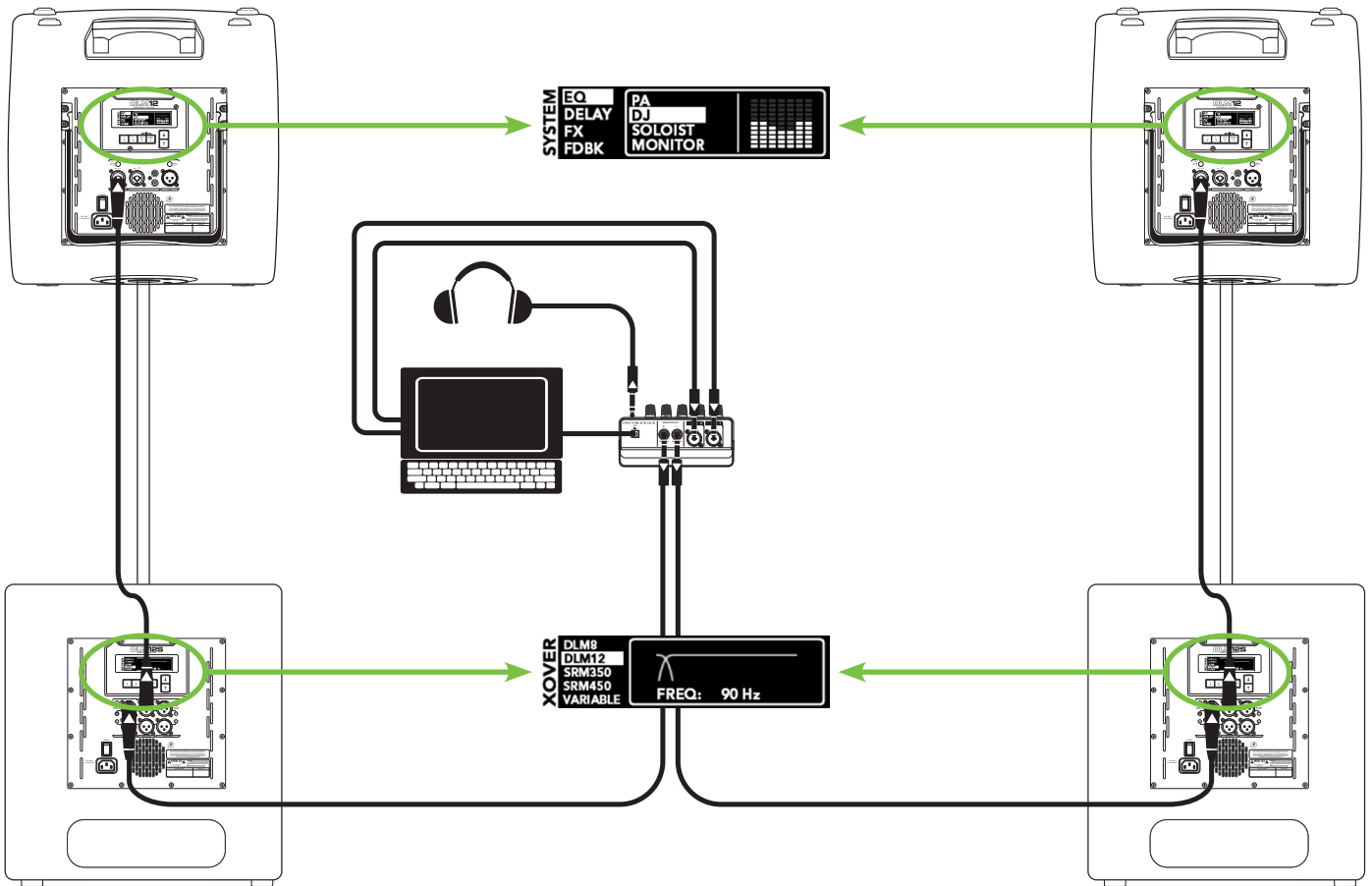

Perhaps you're a DJ playing bumpin' tunes in the middle of the night to a crowd that's groovin' and dancin' to your fine selection.

In this example, a laptop is connected to the channel 1 and 2 inputs of a Mackie Onyx Blackjack and a set of headphones are connected to the phones jack.

The L/R monitor outputs of the Mackie Onyx Blackjack are connected directly to the channel A inputs of each DLM12S subwoofer.

The channel A high pass output of each Mackie DLM12S subwoofer are connected directly to the channel 1 input of each Mackie DLM loudspeaker. Be sure the mic/line switch is OUT. Or be ready to be blasted with an additional 30 dB! Select the DLM12 crossover on the DLM12S for a perfectly matched system tuning.

For the output, you will want to set a speaker mode, described in detail in the DLM loudspeaker manual. For this type of setup, we recommend selecting either the PA or DJ speaker mode. The DJ speaker mode has more bass and sparkling high end. Try them both out and go with the one that best suits your needs.

DJ System

Hookup Diagrams continued...

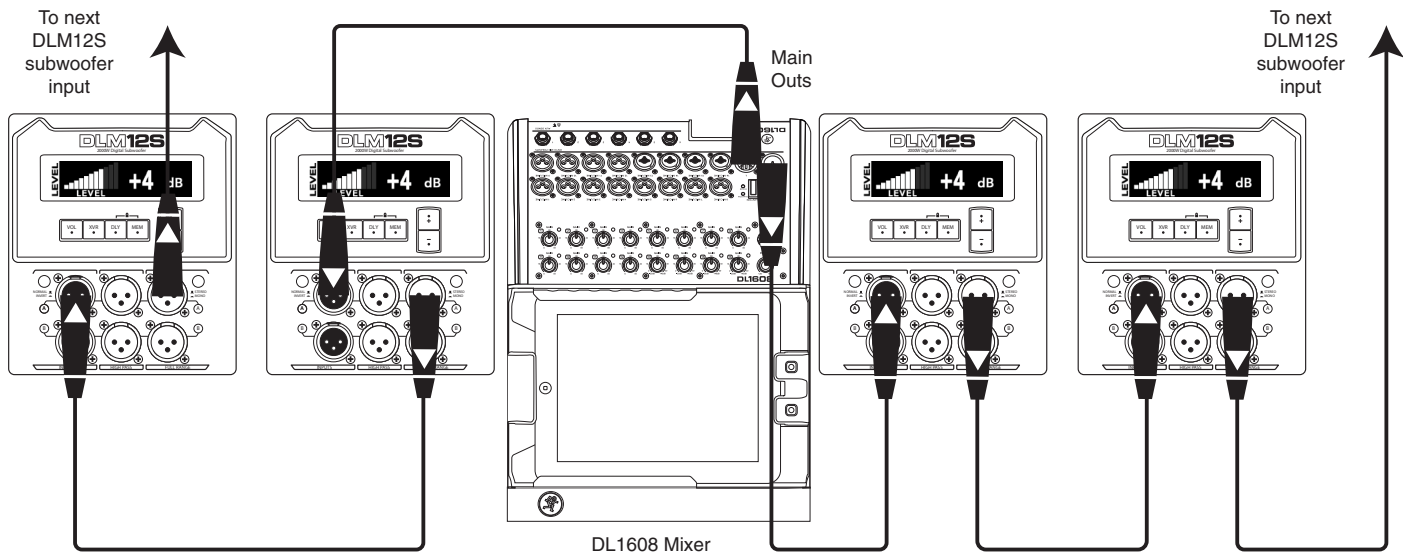

DLM12S subwoofers may be daisy-chained via the male XLR connector labeled "FULL RANGE". Simply plug the signal source (i.e., mixer output) into the input jack(s), and patch that subwoofer's full range jack to the next subwoofers's input jack, and so on, daisy-chaining multiple DLM12S subwoofers. See above for a visual representation of daisy-chaining.

The full range jacks on DLM12S subwoofers are fully buffered with 100 Ω balanced output impedance drivers, so there is no additional loading to the inputs when daisy-chaining. In other words, you could conceivably daisy-chain DLM subwoofers indefinitely.

Daisy-Chaining Multiple DLM12S Subwoofers

Hookup Diagrams continued...

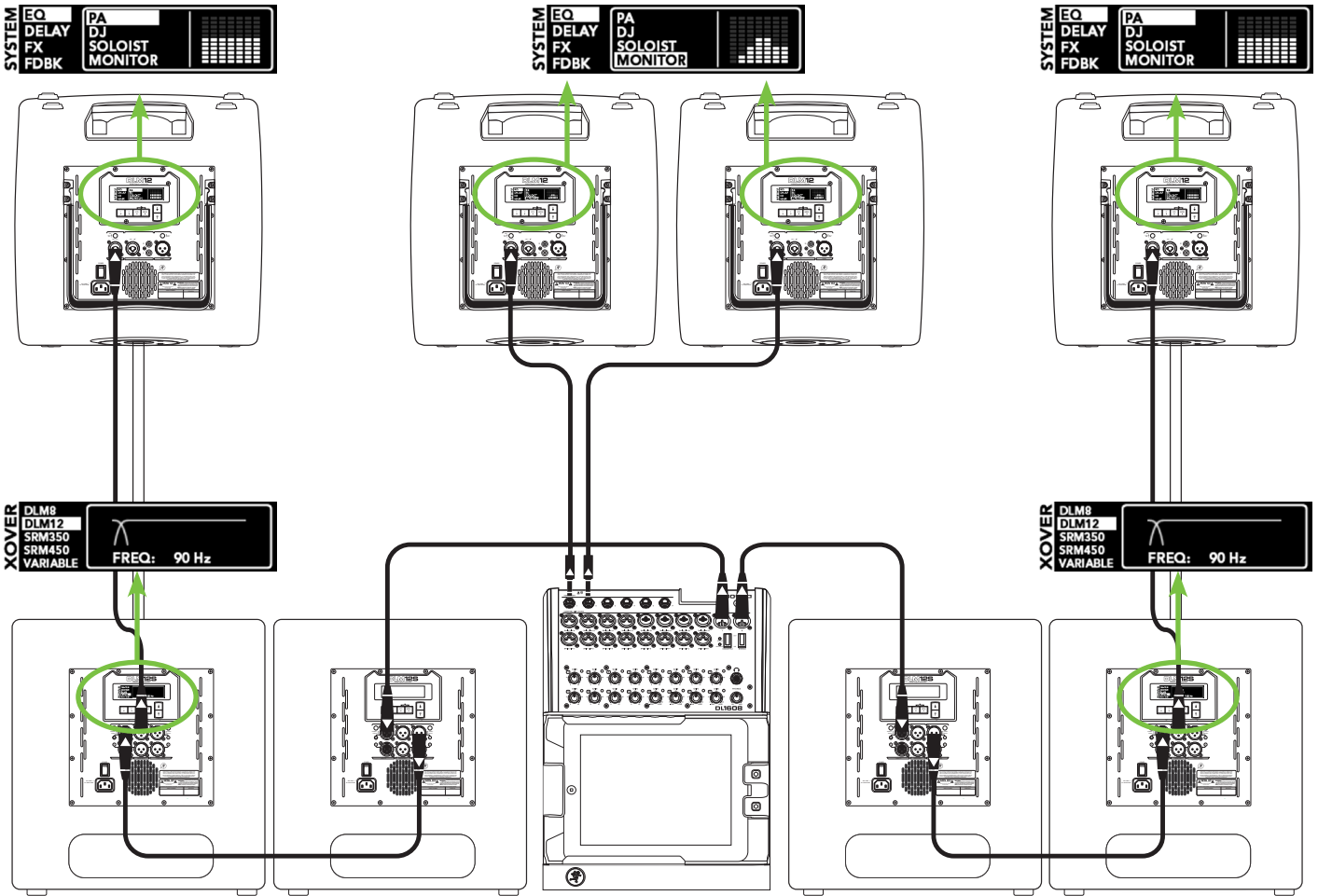

Here's how to set up a large club system using all Mackie gear. In this example, the L/R outputs of a Mackie DL1608 mixer are connected directly to the channel A inputs of two DLM12S subwoofers. The channel A full range outputs of these two DLM12S subwoofers are connected directly to the channel A inputs of another set of DLM12S subwoofers. Talk about beefy low end, that's 8000 watts, yo! And we've only connected the subs.

The channel A high pass outputs of the last two DLM12S subwoofers are connected directly to the channel 1 inputs of the main pair of DLM loudspeakers. Be sure the mic/line switch is OUT. Or be ready to be blasted with an additional 30 dB! Select the DLM12 crossover on each DLM12S for a perfectly matched system tuning.

DLM loudspeakers are also perfect for using as stage monitors. Simply connect a cable from an aux send to the channel 1 input of a DLM loudspeaker. For the aux to monitor output, you will want to set a speaker mode, described in detail in the DLM loudspeaker manual. Since these are monitors, select the appropriately named monitor speaker mode.

Select PA speaker mode for the main loudspeakers. You will want to turn the feedback eliminator ON on all four DLM loudspeakers, as described in the DLM loudspeaker manual.



Large Club System

DLM12S Subwoofer: Rear Panel Features

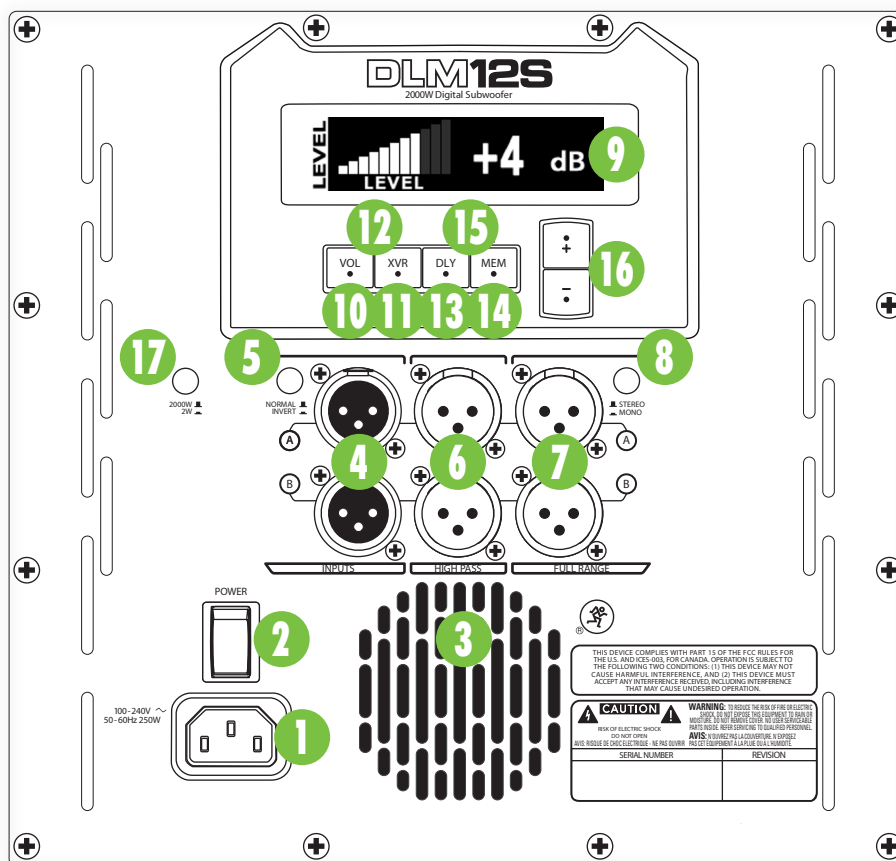

1. Power Connection

This is a standard 3-prong IEC power connector. Connect the detachable power cord (included in the packaging with the subwoofer) to the power receptacle, and plug the other end of the power cord into an AC outlet.



Make sure that the AC power is matched to the AC power indicated on the rear panel (to the left of the IEC receptacle).



Disconnecting the plug's ground pin is dangerous. Don't do it!

2. Power Switch

Press the top of this rocker switch inwards to turn on the subwoofer. The front panel power LED will glow with happiness...or at least it will if the subwoofer is plugged into a suitable live AC mains supply.

Press the bottom of this rocker switch inwards to turn off the subwoofer.



As a general guide, the mixer (or other signal source) should be turned on first, DLM12S subwoofers next, and loudspeakers last.

As such, the loudspeakers should also be turned off first, followed by the subwoofers, then the mixer. This will reduce the possibility of any turn-on or turn-off thumps and other noises generated by any upstream equipment from coming out of the speakers.

3. Fan Vents



Do not obstruct the ventilation openings of the subwoofer. Fans move air over the heatsinks to cool down the power transistors.

If these vents are restricted, then the subwoofer may overheat and shut down.

4. XLR Inputs

Balanced XLR female connectors are provided for the left and right inputs. Connect the full-range line-level signal from the mixer (or other signal source) to these input jacks.

If you are connecting a single subwoofer output, or LFE (low-frequency effects) output to the subwoofer, you may use either the A or B input connector.



NEVER connect the output of an amplifier directly to the input of the subwoofer. This could damage the input circuitry of the active subwoofer.

DLM12S Subwoofer: Rear Panel Features continued...

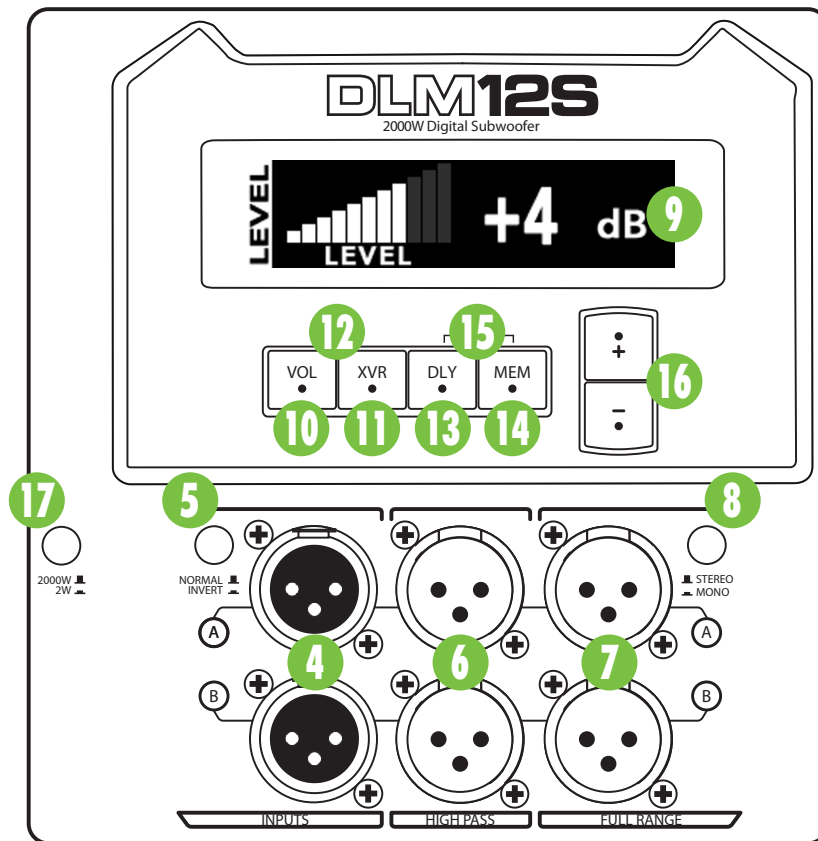

5. Normal/Invert Switch (Polarity)

This switch reverses the polarity of the signal going into the subwoofer amplifier by 180°. It has no effect on the signal at the outputs.

There is no right or wrong setting for this switch. Listen to the overall blend of the subwoofer with the rest of the system and select the switch position that gives you the best sound for your audience. In fact, your system may vary when positioned differently and in alternate venues. Don't be afraid to experiment with the position of the polarity switch. See page 14 for more information.

6. High Pass Outputs

Typically, full-range loudspeakers are connected to the high pass outputs to “split” the work with the DLM12S subwoofer. The subwoofer handles all of the low frequencies and the loudspeakers handle the rest. As a result, it is more efficient and a bit louder.

Balanced XLR male connectors are provided for the line-level A and B high pass outputs. The subwoofer's crossover splits the input signals into two frequency bands. The low frequency range below 20 Hz – 200 Hz goes to the internal amplifier that powers the subwoofer. The frequency range above 20 Hz – 200 Hz is sent to these line-level output jacks. The frequency range depends on where the crossover (XVR) [11] is set.

7. Full Range Outputs

Connect the full range outputs to the inputs of another powered subwoofer, powered loudspeakers, or to an amplifier powering passive loudspeakers. Balanced XLR male connectors are provided for the line-level A and B full range outputs.

The signal at these outputs is a direct copy of the input signals. These outputs allow you to daisy-chain multiple subwoofers and/or send the full range signals to loudspeakers. It's a great way to add side fills, too! See page 7 to learn more about daisy-chaining DLM12S subwoofers.

8. Stereo/Mono Switch (Full Range)

This switch allows you to choose whether the A and B inputs are sent out separately [switch out] or as a mono sum of both inputs [switch in].

For example, if a mixer's L/R outputs are connected to the A and B inputs of a DLM12S subwoofer and the full range outputs are connected to strategically placed DLM loudspeakers, engage the switch so the signal is mono-summed. Otherwise, you'll get just the left or right signal from the mixer's output sent from the A and B full range outputs to the DLM loudspeakers.

DLM12S Subwoofer: Rear Panel Features continued...

9. OLED Display

The OLED Display is one of the most vital features of the DLM12S subwoofer. It displays subwoofer information including (but not limited to) volume, selected crossover, delay settings and other parameters.

When a DLM12S subwoofer is powered up, the last state it was in will load up and the OLED Display will present the volume screen and settings.

DLM12S subwoofers will display a running Running Man screensaver if parameters haven't been changed in awhile. Simply touch one of the DLP buttons to "wake up" the OLED Display.

10. VOL Button



Volume [VOL] adjusts the overall signal level at the inputs to the built-in amplifiers. Press the VOL button to access and update the subwoofer's volume and change the volume by pressing the + or – button [16] repeatedly until you have reached the desired volume. The volume ranges from off ($-\infty$ dB) to +10 dB.

11. XVR Button



The DLM12S crossover [XVR] allows you to choose from a list of preset crossover frequencies for Mackie loudspeakers, as noted below. This optimizes the subwoofer and loudspeakers connected to the DLM12S high pass outputs. If not using DLM or SRM loudspeakers, a variable mode allows you to select the best crossover frequency suited for your PA system from 60 Hz to 120 Hz.

Frequencies below the selected crossover frequency are sent to the subwoofer while frequencies above the selected crossover frequency are sent to the high pass outputs [6]. The crossover frequency should be set to the lowest frequency response rating of the main loudspeakers. Press the XVR button repeatedly until the desired crossover setting is highlighted.

- DLM8 : 110 Hz
- DLM12 : 90 Hz
- SRM350 : 100 Hz
- SRM450 : 95 Hz
- Variable : 60 Hz – 120 Hz

The last one listed – variable – may be set to taste. Simply press the + or – button [16] repeatedly until you have achieved the crossover point you desire. It ranges from 60 Hz to 120 Hz.

12. Front LED On / Limit / Off



Pressing the VOL [10] and XVR [11] buttons simultaneously gives you the option to turn the front LED on, off or limit. Press the + or – button [16] to make a choice, followed by any other button to exit the screen. Choosing limit means the LED is on full-time. However, it will flicker when the limiter is active [3 dB of attenuation, averaged].

13. DLY Button



Delay "delays" the audio signal for a set period of time. With the DLM12S subwoofer, it's used for aligning delay stacks, balcony fills, etc, not as an effect.

Press the DLY button to access and update the subwoofer's delay. Change the delay by pressing the + or – button [16] repeatedly until you have reached the desired delay. Delay times range from 0 ms [0.0 feet / 0.0 meters] to 300 ms [337.8 feet / 102.9 meters].

14. MEM Button

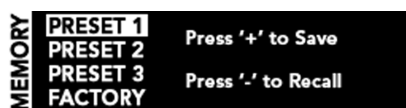

Settings for DLM subwoofers may be saved to memory and recalled at a later time by utilizing the memory [MEM] button.

Press this button repeatedly until the preset spot you want to save settings to (or recall settings from) is highlighted. There are three user presets and a fourth to recall the factory default settings.

Once the preset you want to save to (or recall from) is highlighted, press the "+" button [16] to save the current settings or press the "-" button to recall a preset that was previously saved.

15. Control Lock



The DLM12S interface may be locked by pressing the DLY [13] and MEM [14] buttons simultaneously. An image of a padlock will appear to indicate that the subwoofer is locked. When locked, the DLM12S is safe from accidental button presses. Simply press the buttons again to unlock the subwoofer.

16. + and - Buttons

These buttons work in conjunction with the buttons mentioned previously: VOL, XVR, DLY and MEM. Increase or decrease the volume [10], change the variable frequency band [11], change the delay time/distance [13] and use these buttons to save and recall presets [14].

17. 2000W/2W Switch¹

At Mackie we are always striving to push the envelope, dreaming up new awesome products to design in order to expand the boundaries of the pro audio world. As such, sometimes the little guy gets left out. Not here!

Leave this switch out when you want to run the subwoofer as intended. We designed it with 2000W in mind, so leave this switch out to keep it at 2000W.

Or push this switch in to run the subwoofer at a mere 2W instead. This is a great trick for fooling friends into wondering, “what’s that noise I barely hear?” They will be shocked that it’s your 2000W DLM12S subwoofer running at 2W!

¹ People want more power, not less! As such, this “feature” has been shelved. Power to the people!

Smart Protect

There are advanced DSP protection mechanisms designed into the DLM12S to safeguard the subwoofers and amplifiers from inadvertent damage.



The protection circuits are designed to protect the subwoofers under reasonable and sensible conditions. Should you choose to ignore the warning signs [e.g. excessive distortion], you can still damage the speaker in the DLM12S by overdriving it past the point of amplifier clipping. Such damage is beyond the scope of the warranty.

Limiting

The driver has its own compression circuit which helps protect it from damaging transient peaks. The compressor is designed to be transparent and is not noticeable under normal operating conditions. The front LED will pulse when in limit. Turn the volume down!

Overexcursion Protection

A 36 dB/octave high-pass filter at 32 Hz just prior to the low-frequency amplifier prevents very low frequencies from being amplified. Excessive low-frequency energy below 29 Hz can damage the woofer by causing it to “bottom out,” also known as overexcursion, which is equivalent to a mechanical form of clipping.

Thermal Protection

All amplifiers produce heat. The DLM12S is designed to be efficient both electrically and thermally.

The amplifier module has internal heatsinks and a digitally controlled variable speed fan. As the DSP recognizes varying internal heat levels, it will turn on at an appropriate speed to draw cool air in over the amplifier and exit via the side vents.

In the unlikely event of the amplifier overheating, a built-in thermal switch will activate, muting the signal and ramping the fan up to top speed. An error message will also appear on the OLED Display.

OVERTEMP!

When the amplifier has cooled down to a safe operating temperature, the thermal switch resets itself, and the DLM12S subwoofer resumes normal operation.

If the thermal switch activates, try turning down the level control a notch or two on the mixing console (or the back of the subwoofer) to avoid overheating the amplifier. Be aware that direct sunlight and/or hot stage lights may be the culprit of an amplifier overheating.

FYI

UI Version	X.X.X
DSP Version	X.X.X
Amp B+	XX.X
Temperature	XX.X

The FYI screen displays the latest UI version, DSP version, Amp B+ [voltage] and current temperature. Nothing may be changed or updated here, just an FYI, as stated. This screen is displayed when pressing the VOL [10] and MEM buttons [14] simultaneously.

AC Power

Be sure the DLM12S subwoofer is plugged into an outlet that is able to supply the correct voltage specified for your model. It will continue to operate at lower voltages, but will not reach full power.

Be sure the electrical service can supply enough amperage for all the components connected to it.

We recommend that a stiff (robust) supply of AC power be used because the amplifiers place high current demands on the AC line. The more power that is available on the line, the louder the speakers will play and the more peak output power will be available for a cleaner, punchier bass. A suspected problem of “poor bass performance” is often caused by a weak AC supply to the amplifiers.

Be aware of any error messages that may be displayed on the OLED Display. Overvoltage, for example.

ERROR!

OVERVOLTAGE!



Never remove the ground pin on the power cord or any other component of the DLM12S subwoofer. This is very dangerous.

Placement

The DLM12S subwoofer is designed to sit on the floor or stage. It is not designed to be pole-mounted or suspended.

When pole-mounting loudspeakers, be sure that the DLM12S subwoofers are stabilized and secured from falling over or being accidentally pushed over. For stacked scenarios, it is highly suggested that straps are utilized. Failure to follow these precautions may result in damage to the equipment, personal injury, or death.



The cabinet has no rigging points and is not suitable for rigging. NEVER attempt to suspend a DLM12S subwoofer by its handles.

As with any powered components, protect them from moisture and extreme cold and follow the other Care and Maintenance suggestions below.

The Ins and Outs of Polarity

The Mackie DLM12S subwoofer includes a switch that allows you to quickly invert the polarity of the subwoofer's output relative to the input signal it is receiving from the mixer or other sound source. But what exactly does that mean? A subwoofer works by literally pumping air as the woofer cone moves in and out with respect to the cabinet in which it is housed. It does so according to the low-frequency portion of the signal it receives from the sound source.

The woofer cone is simply following the waveform as seen in the sine wave in Figure 1. As the sine wave rises, the woofer cone pushes out. Likewise, as the sine wave falls, the woofer cone pulls into the cabinet. A musical signal is much more complex, of course, but the same principle applies. Movement of the woofer cone causes air pressure changes that we perceive as sound.

When the normal/invert [polarity] switch [5] is engaged, the original waveform is simply reversed 180° [see Figure 2]. Again, the subwoofer cone follows the waveform. However, this time the woofer cone starts by pulling into the cabinet followed by the woofer cone pushing out. If you have ever experimented with a subwoofer polarity switch, you may not have noticed any changes to the sound regardless of its position, especially if you are listening to just the subwoofer. This is normal, as our ears perceive them both at the same time.

The normal/invert [polarity] switch comes into play when the DLM12S subwoofer is paired with a loudspeaker. Ideally, the woofer cones of the subwoofer and full range loudspeaker would work together by pushing and pulling in unison. DLM12S subwoofers are designed to be used in a broad range of applications. The flexibility provided by the polarity switch is necessary to ensure that you are receiving the best possible sound from your system, regardless of your setup.

Care and Maintenance

Your Mackie subwoofers will provide many years of reliable service if you follow these guidelines:

- Avoid exposing the subwoofers to moisture. If they are set up outdoors, be sure they are under cover if rain is expected.
- Avoid exposure to extreme cold (below freezing temperatures). If you must operate the subwoofers in a cold environment, warm up the voice coils slowly by sending a low-level signal through them for about 15 minutes prior to high-power operation.
- Use a dry cloth to clean the cabinets. Only do this when the power is turned off. Avoid getting moisture into any of the openings of the cabinet, particularly where the drivers are located.

Polarity Waveforms

Figure 1: Normal [0°]

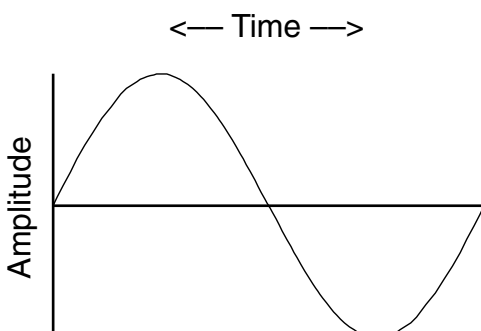
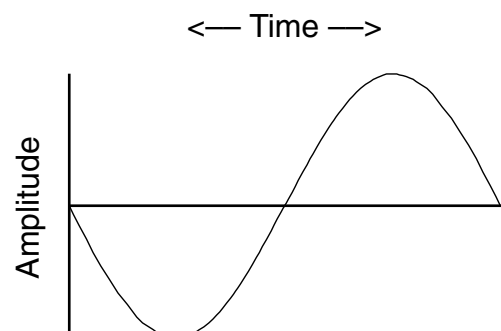

Figure 2: Invert [180°]



Appendix A: Service Information

If you think your Mackie product has a problem, please check out the following troubleshooting tips and do your best to confirm the problem. Visit the Support section of our website (www.mackie.com/support) where you will find lots of useful information such as FAQs and other documentation. You may find the answer to the problem without having to send your Mackie product away.

Troubleshooting

No power

- Our favorite question: Is it plugged in? Make sure the AC outlet is live [check with a tester or lamp].
- Our next favorite question: Is the power switch on? If not, try turning it on.
- Make sure the line cord is securely seated in the line cord socket and plugged all the way into the AC outlet.
- Is the power LED on the front panel glowing green? If not, make sure the AC outlet is live. If so, refer to “No sound” below.
- The internal AC line fuse may be blown. This is not a user serviceable part. If you suspect the AC line fuse is blown, please see the "Repair" section next.

No sound

- Is the input level control for the input source turned all the way down? Verify that all the volume controls in the system are properly adjusted. Look at the level meter to ensure that the mixer is receiving a signal.
- Is the signal source working? Make sure the connecting cables are in good repair and securely connected at both ends. Make sure the output volume (gain) control on the mixing console is turned up sufficiently to drive the inputs of the speaker.
- Make sure the mixer does not have a mute on or a processor loop engaged. If you find something like this, make sure the volume/gain is turned down before disengaging the offending switch.
- Has it shut down? Make sure there is at least six inches of free space behind each DLM subwoofer.

Poor bass performance

- Check the polarity of the connections between the mixer and the subwoofers. You may have your positive and negative connections reversed at one end of one cable, causing one subwoofer to be out-of-phase with the other.
- Poor bass performance may be the result of bad AC power. See the section titled ‘AC Power’ on the previous page for further details.

Poor sound

- Is it loud and distorted? Make sure that you're not overdriving a stage in the signal chain. Verify that all level controls are set properly.
- Is the input connector plugged completely into the jack? Be sure all connections are secure.

Noise

- Make sure all connections to the active subwoofers are good and sound.
- Make sure none of the signal cables are routed near AC cables, power transformers, or other EMI-inducing devices.
- Is there a light dimmer or other SCR-based device on the same AC circuit as the DLM12S? Use an AC line filter or plug the subwoofer into a different AC circuit.

Hum

- Try disconnecting the cable connected to the input jack. If the noise disappears, it could be a “ground loop,” rather than a problem with the DLM12S subwoofer. Try some of the following troubleshooting ideas:
- Use balanced connections throughout your system for the best noise rejection.
- Whenever possible, plug all the audio equipment's line cords into outlets which share a common ground. The distance between the outlets and the common ground should be as short as possible.

Repair

For warranty service, refer to the warranty information on page 21.

Non-warranty service for Mackie products is available at a factory-authorized service center. To locate the nearest service center, visit www.mackie.com, click “Support” and select “Locate a Service Center.” Service for Mackie products living outside the United States can be obtained through local dealers or distributors.

If you do not have access to our website, you may call the Tech Support department at 1-800-898-3211, Monday-Friday, during normal business hours, Pacific Time, to explain the problem. Tech Support will tell you where the nearest factory-authorized service center is located in your area.

Appendix B: Connections

XLR Connectors

Each DLM12S subwoofer has two female XLR inputs. Be sure the cables are wired per AES (Audio Engineering Society) standards:

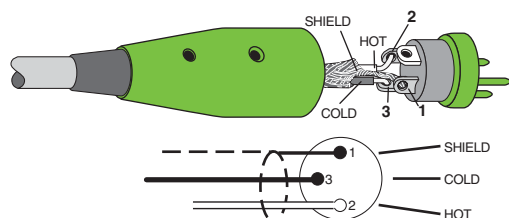

XLR Input Connector

XLR

- Pin 1 – Shield (Ground)
- Pin 2 – Hot (+)
- Pin 3 – Cold (-)

There are also four male balanced XLR output connectors on each DLM12S subwoofer [2 high pass and 2 full range]. These are also wired according to the AES standards listed above.

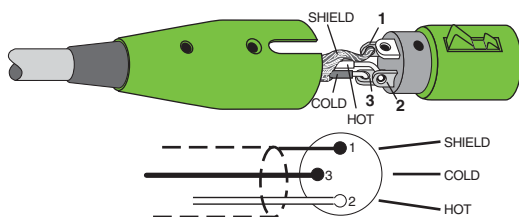

Balanced XLR Output Connectors

DLM12S subwoofers may be daisy-chained via the male XLR connector labeled “FULL RANGE”. Simply plug the signal source (i.e., mixer output) into the input jack(s), and patch that subwoofer’s full range jack to the next subwoofers’s input jack, and so on, daisy-chaining multiple DLM12S subwoofers. See page 7 for a visual representation of daisy-chaining.

The full range jacks on DLM12S subwoofers are fully buffered with 100 Ω balanced output impedance drivers, so there is no additional loading to the inputs when daisy-chaining. In other words, you could conceivably daisy-chain DLM subwoofers indefinitely.

Appendix C: Technical Information

DLM12S Subwoofer Specifications

Acoustic Performance:

Frequency Response (-10 dB)	35 Hz, User-selectable 90 Hz – 135 Hz
Max peak SPL (@ 1m calculated) ¹	128 dB
Crossover Point	User-selectable 60 Hz – 120 Hz
Horizontal Coverage	N/A
Vertical Coverage	N/A

Transducer

Woofers Diameter	12.0 in / 305 mm
Voice Coil Diameter	3 in / 76 mm
Diaphragm Material	Paper
Magnet Material	Ferrite

Power Amplifier

Rated Power	1000 watts rms 2000 watts peak
Rated THD	< 1%
Cooling	Multi-speed fan
Design	Class D

DLP Digital System Processing

Volume [VOL]	Off ($-\infty$ dB) to +10 dB
Crossover [XVR]	Four preset xvr modes, one variable xvr mode
Delay [DLY]	0-300 ms
Memory [MEM]	Three locations for instant venue setting recall and factory reset

Input/Output

Input Type	Female XLR balanced differential (stereo left/right)
Input Impedance	20 k Ω balanced, 10 k Ω unbalanced
Full Range Outputs	Male XLR balanced (parallel with input)
High Pass Outputs	Male XLR balanced

Line Input Power

US detachable line cord	100 – 120 VAC, 50 – 60 Hz, 250W
EU detachable line cord	220 – 240 VAC, 50 – 60 Hz, 250W
AC Connector	3-pin IEC 250 VAC

Safety Features

Input Protection	Peak and RMS limiting, power supply and amplifier thermal protection
Display LEDs	Defeatable front power ON, Front load power limiter
Status Info	Power supply voltage, Core temperature

Construction Features

Cabinet	Extremely durable 15 mm poplar
Finish	High durability black paint
Handles	One on each side
Grille	Powder-coated 20 gauge steel

Physical Properties

Height	17.9 in / 455 mm
Width	16.4 in / 417 mm
Depth	20.8 in / 529 mm
Weight	48 lb / 21.7 kg

Mounting Method

The DLM12S subwoofer is designed to sit on the floor or stage. It is NOT designed to be pole-mounted or suspended. The cabinet has no rigging points and is not suitable for rigging. Never attempt to suspend the DLM12S by its handles.

Disclaimer

Since we are always striving to make our products better by incorporating new and improved materials, components, and manufacturing methods, we reserve the right to change these specifications at any time without notice.

“Mackie” and the “Running Man” figure are registered trademarks of LOUD Technologies Inc.

All other brand names mentioned are trademarks or registered trademarks of their respective holders, and are hereby acknowledged.

©2012 LOUD Technologies Inc.
All Rights Reserved.

¹ Calculated from driver sensitivity and amplifier power.

DLM12S Subwoofer Dimensions

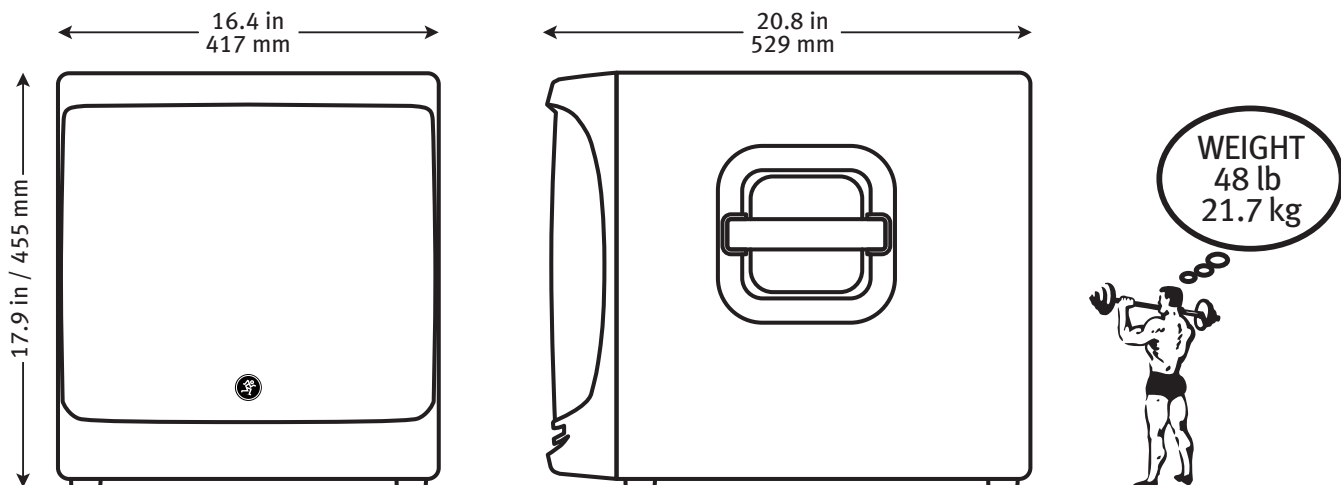

DLM12S Subwoofer Frequency Response

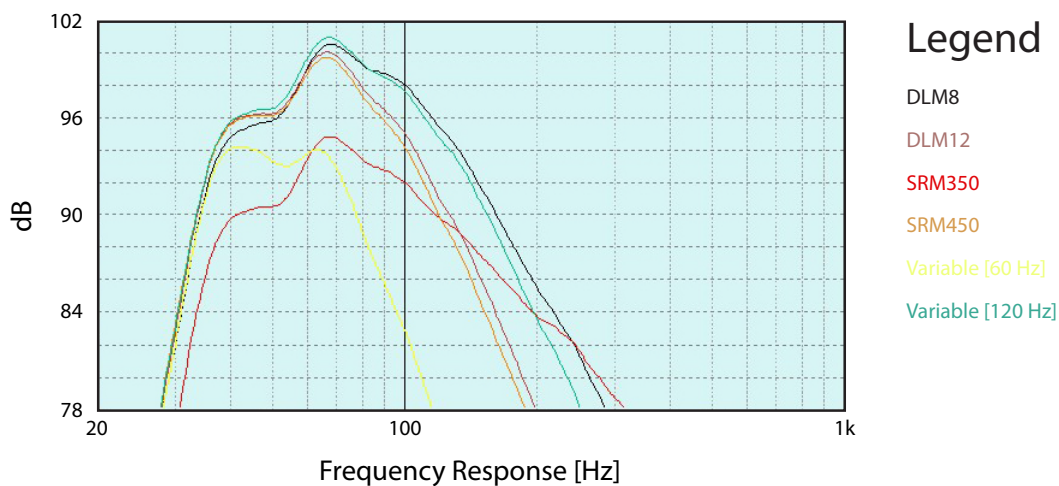

DLM12S Subwoofer Block Diagram

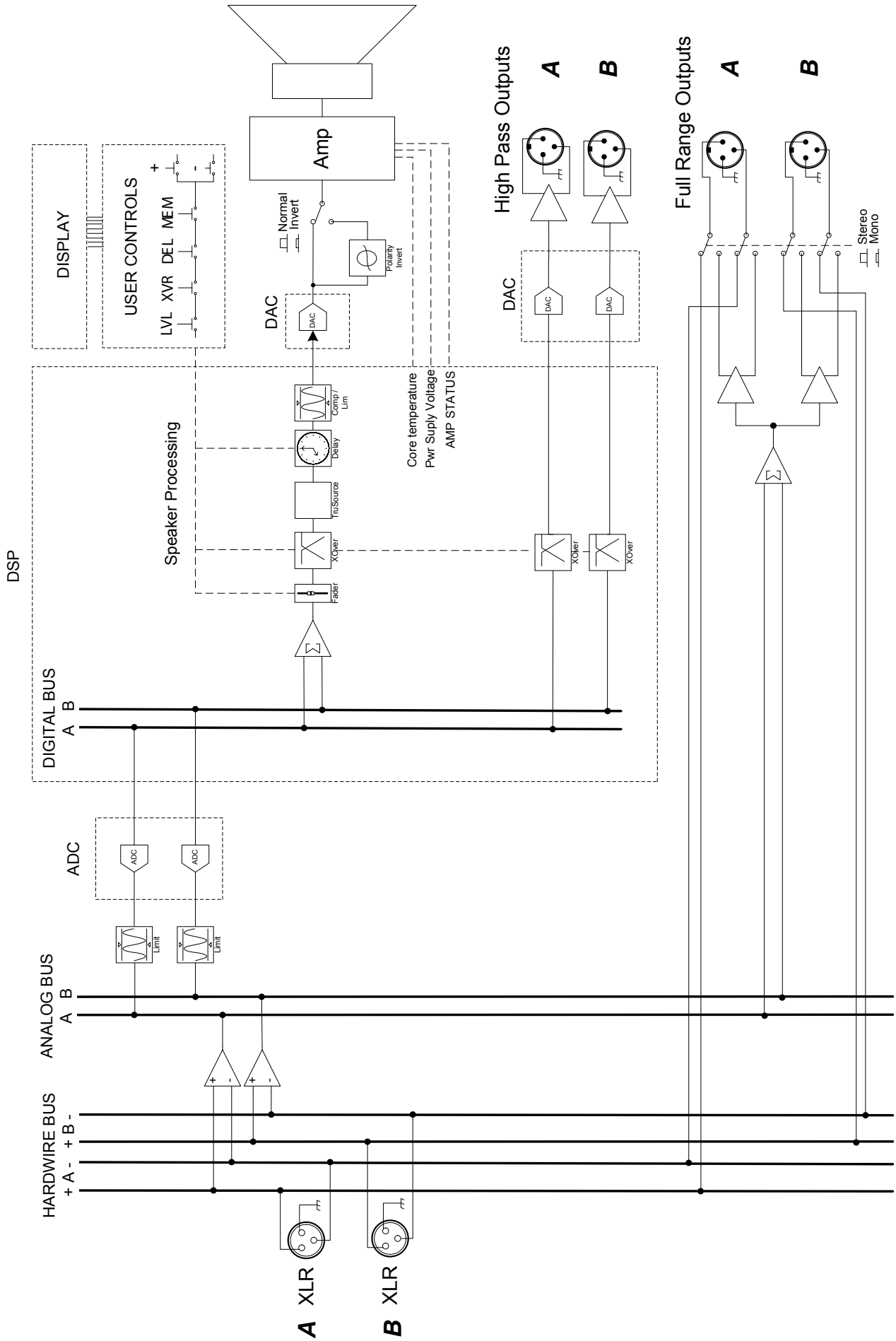

Mackie Limited Warranty

Please keep your sales receipt in a safe place.

This Limited Product Warranty ("Product Warranty") is provided by LOUD Technologies Inc. ("LOUD") and is applicable to products purchased in the United States or Canada through a LOUD-authorized reseller or dealer. The Product Warranty will not extend to anyone other than the original purchaser of the product (hereinafter, "Customer," "you" or "your").

For products purchased outside the U.S. or Canada, please visit www.mackie.com/warranty to find contact information for your local distributor, and information on any warranty coverage provided by the distributor in your local market.

LOUD warrants to Customer that the product will be free from defects in materials and workmanship under normal use during the Warranty Period. If the product fails to conform to the warranty then LOUD or its authorized service representative will at its option, either repair or replace any such nonconforming product, provided that Customer gives notice of the noncompliance within the Warranty Period to the Company at: www.mackie.com/support or by calling LOUD technical support at 1.800.898.3211 (toll-free in the U.S. and Canada) during normal business hours Pacific Time, excluding weekends or LOUD holidays. Please retain the original dated sales receipt as evidence of the date of purchase. You will need it to obtain any warranty service.

For full terms and conditions, as well as the specific duration of the Warranty for this product, please visit www.mackie.com/warranty.

The Product Warranty, together with your invoice or receipt, and the terms and conditions located at www.mackie.com/warranty constitutes the entire agreement, and supersedes any and all prior agreements between LOUD and Customer related to the subject matter hereof. No amendment, modification or waiver of any of the provisions of this Product Warranty will be valid unless set forth in a written instrument signed by the party to be bound thereby.

Need help with your subwoofer?

- Visit www.mackie.com and click Support to find: FAQs, manuals, addendums, and other documents.
- Email us at: techmail@mackie.com.
- Telephone 1-800-898-3211 to speak with one of our splendid technical support chaps (Monday through Friday, normal business hours, Pacific Time).



16220 Wood-Red Road NE
Woodinville, WA 98072 • USA
Phone: 425.487.4333
Toll-free: 800.898.3211
Fax: 425.487.4337
www.mackie.com
